



Fast servo controller



Version 1.0.3, Rev 2-4 hardware

Limitation of Liability

MOG Laboratories Pty Ltd (MOGLabs) does not assume any liability arising out of the use of the information contained within this manual. This document may contain or reference information and products protected by copyrights or patents and does not convey any license under the patent rights of MOGLabs, nor the rights of others. MOGLabs will not be liable for any defect in hardware or software or loss or inadequacy of data of any kind, or for any direct, indirect, incidental, or consequential damages in connections with or arising out of the performance or use of any of its products. The foregoing limitation of liability shall be equally applicable to any service provided by MOGLabs.

Copyright

Copyright © MOG Laboratories Pty Ltd (MOGLabs) 2017 – 2021. No part of this publication may be reproduced, stored in a retrieval system, or transmitted, in any form or by any means, electronic, mechanical, photocopying or otherwise, without the prior written permission of MOGLabs.

Contact

For further information, please contact:

MOG Laboratories P/L
49 University St
Carlton VIC 3053
AUSTRALIA
+61 3 9939 0677
info@moglabs.com

MOGLabs USA LLC
419 14th St
Huntingdon PA 16652
USA
+1 814 251 4363
www.moglabs.com

Contents

| | | |
|----------|---|-----------|
| 1 | Introduction | 1 |
| 1.1 | Basic feedback control theory | 1 |
| 2 | Connections and controls | 5 |
| 2.1 | Front panel controls | 5 |
| 2.2 | Rear panel controls and connections | 9 |
| 2.3 | Internal DIP switches | 11 |
| 3 | Feedback control loops | 13 |
| 3.1 | Input stage | 14 |
| 3.2 | Slow servo loop | 14 |
| 3.3 | Fast servo loop | 18 |
| 3.4 | Modulation and scanning | 22 |
| 4 | Application example: Pound-Drever Hall locking | 23 |
| 4.1 | Laser and controller configuration | 24 |
| 4.2 | Achieving an initial lock | 25 |
| 4.3 | Optimisation | 28 |
| A | Specifications | 33 |
| B | Troubleshooting | 35 |
| B.1 | Laser frequency not scanning | 35 |
| B.2 | When using modulation input, the fast output floats to a large voltage | 36 |
| B.3 | Large positive error signals | 36 |
| B.4 | Fast output rails at ± 0.625 V | 36 |
| B.5 | Feedback needs to change sign | 36 |
| B.6 | Monitor outputs wrong signal | 37 |

| | |
|--|-----------|
| B.7 Laser undergoes slow mode hops | 37 |
| C PCB layout | 39 |
| D 115/230 V conversion | 41 |
| D.1 Fuse | 41 |
| D.2 120/240 V conversion | 41 |
| References | 46 |

1. Introduction

The MOGLabs FSC provides the critical elements of a high-bandwidth low-latency servo controller, primarily intended for laser frequency stabilisation and linewidth narrowing. The FSC can also be used for amplitude control, for example to create a “noise-eater” that stabilises the optical power of a laser, but in this manual we assume the more common application of frequency stabilisation.

1.1 Basic feedback control theory

Feedback frequency stabilisation of lasers can be complicated. We encourage readers to review control theory textbooks [1,2] and literature on laser frequency stabilisation [3].

The concept of feedback control is shown schematically in figure 1.1. The frequency of the laser is measured with a *frequency discriminator* which generates an *error signal* that is proportional to the difference between the instantaneous laser frequency and the desired or *setpoint* frequency. Common discriminators include optical cavities and Pound-Drever-Hall (PDH) [4] or Hänsch-Couillaud [5] detection; offset locking [6]; or many variations of atomic absorption spectroscopy [7–10].

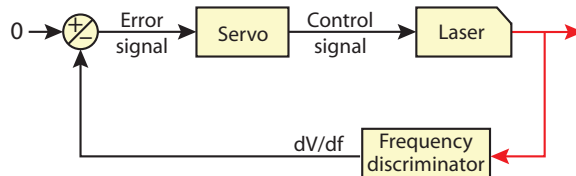

Figure 1.1: Simplified block diagram of a feedback control loop.

1.1.1 Error signals

The key common feature of feedback control is that the error signal used for control should reverse sign as the laser frequency shifts above or below the setpoint, as in figure 1.2. From the error signal, a feedback servo or *compensator* generates a *control signal* for a transducer in the laser, such that the laser frequency is driven towards the desired setpoint. Critically, this control signal will change sign as the error signal changes sign, ensuring the laser frequency always gets pushed towards the setpoint, rather than away from it.

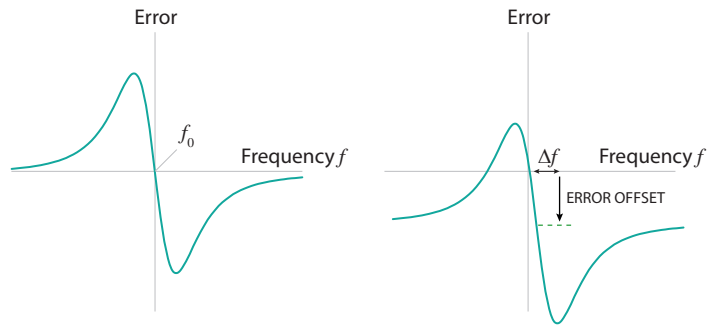

Figure 1.2: A theoretical dispersive error signal, proportional to the difference between a laser frequency and a setpoint frequency. An offset on the error signal shifts the lock point (right).

Note the distinction between an *error signal* and a *control signal*. An error signal is a measure of the difference between the actual and desired laser frequency, which in principle is instantaneous and noise-free. A control signal is generated from the error signal by a feedback servo or compensator. The control signal drives an actuator such as a piezo-electric transducer, the injection current of a laser diode, or an acousto-optic or electro-optic modulator, such that the laser frequency returns to the setpoint. Actuators have complicated response functions, with finite phase lags, frequency-dependent gain, and resonances. A compensator should optimise the control response to reduce the error to the minimum possible.

1.1.2 Frequency response of a feedback servo

The operation of feedback servos is usually described in terms of the Fourier frequency response; that is, the gain of the feedback as a function of the frequency of a disturbance. For example, a common disturbance f_m is mains frequency, $f_m = 50$ Hz or 60 Hz. That disturbance will alter the laser frequency f by some amount, at a rate of 50 or 60 Hz. The effect of the disturbance on the laser might be small (e.g. $f = f_0 \pm 1$ kHz where f_0 is the undisturbed laser frequency) or large ($f = f_0 \pm 1$ MHz). Regardless of the size of this disturbance, the Fourier frequency of the disturbance is either at 50 or 60 Hz. To suppress that disturbance, a feedback servo should have high gain at 50 and 60 Hz to be able to compensate.

The gain of a servo controller typically has a low-frequency limit, usually defined by the gain-bandwidth limit of the opamps used in the servo controller. The gain must also fall below unity gain (0 dB) at higher frequencies to avoid inducing oscillations in the control output, such as the familiar high-pitched squeal of audio systems (commonly called “audio feedback”). These oscillations occur for frequencies above the reciprocal of the minimum propagation delay of the combined laser, frequency discriminator, servo and actuator system. Typically this limit is dominated by the response time of the actuator. For the piezos used in external cavity diode lasers, the limit is typically a few kHz, and for the current modulation response of the laser diode, the limit is around 100 to 300kHz.

Figure 1.3 is a conceptual plot of gain against Fourier frequency for the FSC. To minimise the laser frequency error, the area under the gain plot should be maximised. PID (proportional integral and differential) servo controllers are a common approach, where the control signal is the sum of three components derived from the one input error signal. The proportional feedback (P) attempts to promptly compensate for disturbances, whereas integrator feedback (I) provides high gain for offsets and slow drifts, and differential feedback (D) adds extra gain for sudden changes.

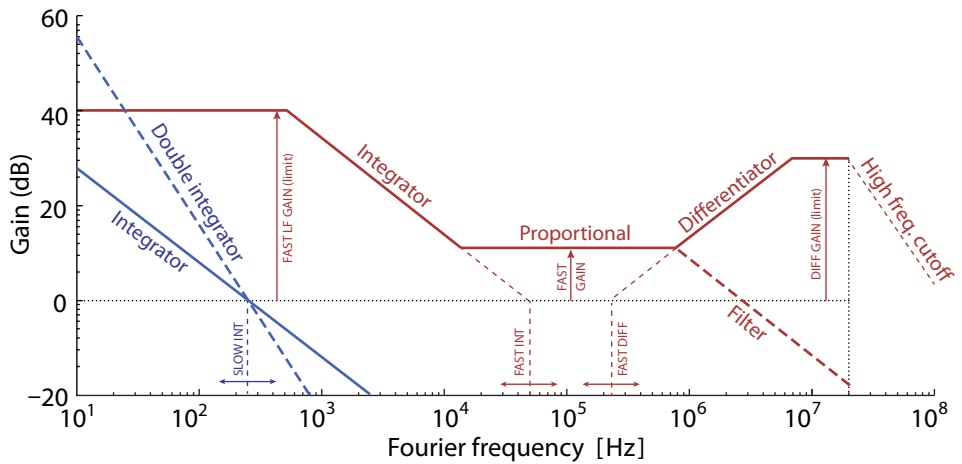

Figure 1.3: Conceptual Bode plot showing action of the fast (red) and slow (blue) controllers. The slow controller is either a single or double integrator with adjustable corner frequency. The fast controller is PID with adjustable corner frequencies and gain limits at the low and high frequencies. Optionally the differentiator can be disabled and replaced with a low-pass filter.

2. Connections and controls

2.1 Front panel controls

The front panel of the FSC has a large number of configuration options that allow the servo behaviour to be tuned and optimised.

Please note that switches and options may vary between hardware revisions, please consult the manual for your specific device as indicated by the serial number.

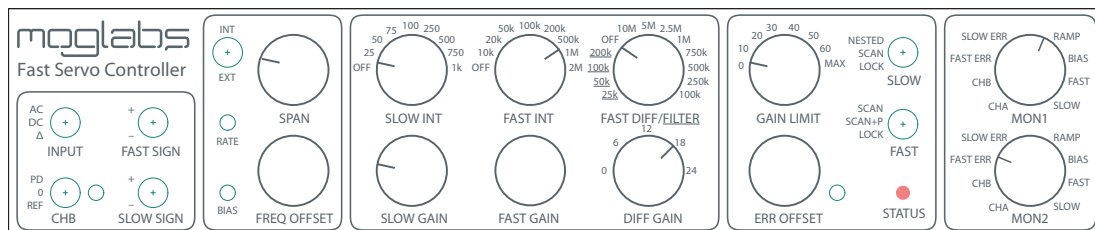

2.1.1 Configuration

INPUT Selects error signal coupling mode; see figure 3.2.

AC Fast error signal is AC-coupled, slow error is DC coupled.

DC Both fast and slow error signals are DC-coupled.

Δ Signals are DC-coupled, and the front-panel ERROR OFFSET is applied for control of the lock point.

CHB Selects input for channel B: photodetector, ground, or a variable 0 to 2.5V reference set with the adjacent trimpot.

FAST SIGN Sign of the fast feedback.

SLOW SIGN Sign of the slow feedback.

2.1.2 Ramp control

The internal ramp generator provides a sweep function for scanning the laser frequency typically via a piezo actuator, diode injection current, or both. A trigger output synchronised to the ramp is provided on the rear panel (TRIG).

INT/EXT Internal or external ramp for frequency scanning.

RATE Trimpot to adjust internal sweep rate.

BIAS When DIP3 is enabled, the slow output, scaled by this trimpot, is added to the fast output. This bias feed-forward is typically required when adjusting the piezo actuator of an ECDL to prevent mode-hopping. However, this functionality is already provided by some laser controllers (such as the MOGLabs DLC) and should only be used when not provided elsewhere.

SPAN Adjusts the ramp height, and thus the extent of the frequency sweep.

FREQ OFFSET Adjusts the DC offset on the slow output, effectively providing a static shift of the laser frequency.

2.1.3 Loop variables

The loop variables allow the gain of the proportional, integrator and differentiator stages to be adjusted. For the integrator and differentiator stages, the gain is presented in terms of the unit gain frequency, sometimes referred to as the corner frequency.

SLOW INT Corner frequency of the slow servo integrator; can be disabled or adjusted from 25 Hz to 1 kHz.

SLOW GAIN Single-turn slow servo gain; from -20 dB to $+20$ dB.

FAST INT Corner frequency of the fast servo integrator; off or adjustable from 10 kHz to 2 MHz.

- FAST GAIN** Ten-turn fast servo proportional gain; from -10 dB to $+50$ dB.
- FAST DIFF/FILTER** Controls the high-frequency servo response. When set to "OFF", the servo response remains proportional. When turned clockwise, the differentiator is enabled with the associated corner frequency. Note that *decreasing* the corner frequency *increases* the action of the differentiator. When set to an underlined value, the differentiator is disabled and instead a low-pass filter is applied to the servo output. This causes the response to roll-off above the specified frequency.
- DIFF GAIN** High-frequency gain limit on the fast servo; each increment changes the maximum gain by 6 dB. Has no effect unless the differentiator is enabled; that is, unless FAST DIFF is set to a value that is not underlined.

2.1.4 Lock controls

- GAIN LIMIT** Low-frequency gain limit on the fast servo, in dB. MAX represents the maximum available gain.
- ERROR OFFSET** DC offset applied to the error signals when INPUT mode is set to Δ . Useful for precise tuning of the locking point or compensating for drift in the error signal. The adjacent trimpot is for adjusting the error offset of the slow servo relative to the fast servo, and may be adjusted to ensure the fast and slow servos drive towards the same exact frequency.
- SLOW** Engages the slow servo by changing SCAN to LOCK. When set to NESTED, the slow control voltage is fed into the fast error signal for very high gain at low frequencies in the absence of an actuator connected to the slow output.
- FAST** Controls the fast servo. When set to SCAN+P, the proportional feedback is fed into the fast output while the laser is scanning, allowing the feedback to be calibrated. Changing to LOCK stops the scan and engages full PID control.

STATUS Multi-colour indicator displaying status of the lock.

Green Power on, lock disabled.

Orange Lock engaged but error signal out of range, indicating the lock has failed.

Blue Lock engaged and error signal is within limits.

2.1.5 Signal monitoring

Two rotary encoders select which of the specified signals is routed to the rear-panel MONITOR 1 and MONITOR 2 outputs. The TRIG output is a TTL compatible output that switches from low to high at the centre of the sweep. The table below defines the signals.

| | |
|-----------------|---|
| CHA | Channel A input |
| CHB | Channel B input |
| FAST ERR | Error signal used by the fast servo |
| SLOW ERR | Error signal used by the slow servo |
| RAMP | Ramp as applied to SLOW OUT |
| BIAS | Ramp as applied to FAST OUT when DIP3 enabled |
| FAST | FAST OUT control signal |
| SLOW | SLOW OUT control signal |

2.2 Rear panel controls and connections

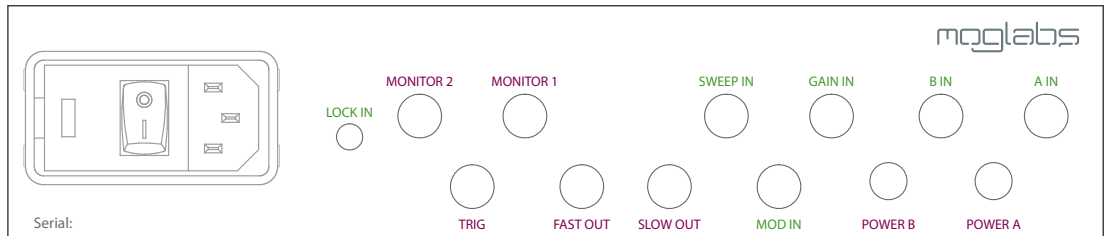

All connectors are SMA, except as noted. All inputs are over-voltage protected to ± 15 V.

- IEC power in** The unit should be preset to the appropriate voltage for your country. Please see appendix D for instructions on changing the power supply voltage if needed.
- A IN, B IN** Error signal inputs for channels *A* and *B*, typically photodetectors. High impedance, nominal range ± 2.5 V. Channel *B* is unused unless the CHB switch on the front-panel is set to PD.
- POWER A, B** Low-noise DC power for photodetectors; ± 12 V, 125 mA, supplied through an M8 connector (TE Connectivity part number 2-2172067-2, Digikey A121939-ND, 3-way male). Compatible with MOGLabs PDA and Thorlabs photodetectors. To be used with standard M8 cables, for example Digikey 277-4264-ND. Ensure that photodetectors are switched off when being connected to the power supplies to prevent their outputs railing.
- GAIN IN** Voltage-controlled proportional gain of fast servo, ± 1 V, corresponding to the full-range of the front-panel knob. Replaces front-panel FAST GAIN control when DIP1 is enabled.
- SWEEP IN** External ramp input allows for arbitrary frequency scanning, 0 to 2.5 V. Signal must cross 1.25 V, which defines the centre of the sweep and the approximate lock point.

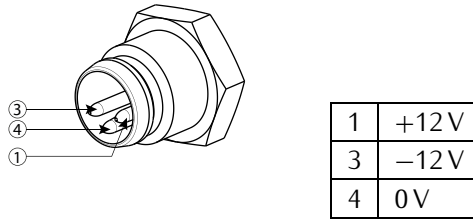

Figure 2.1: M8 connector pinout for POWER A, B.

- MOD IN** High-bandwidth modulation input, added directly to fast output, $\pm 1\text{ V}$ if DIP4 is on. Note that if DIP4 is on, MOD IN should be connected to a supply, or properly terminated.
- SLOW OUT** Slow control signal output, 0V to 2.5V. Normally connected to a piezo driver or other slow actuator.
- FAST OUT** Fast control signal output, $\pm 2.5\text{ V}$. Normally connected to diode injection current, acousto- or electro-optic modulator, or other fast actuator.
- MONITOR 1, 2** Selected signal output for monitoring.
- TRIG** Low to high TTL output at sweep centre.
- LOCK IN** TTL scan/lock control; 3.5 mm stereo connector, left/right (pins 2, 3) for slow/fast lock; low (ground) is active (enable lock). Front-panel scan/lock switch must be on SCAN for LOCK IN to have effect. Digikey cable CP-2207-ND provides a 3.5 mm plug with wire ends; red for slow lock, thin black for fast lock, and thick black for ground.

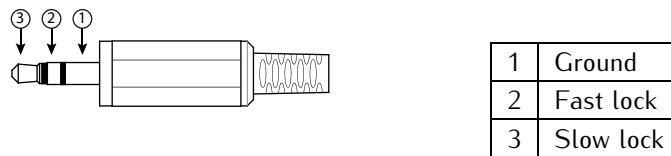

Figure 2.2: 3.5 mm stereo connector pinout for TTL scan/lock control.

2.3 Internal DIP switches

There are several internal DIP switches that provide additional options, all set to OFF by default.

WARNING There is potential for exposure to high voltages inside the FSC, especially around the power supply.

| | | OFF | ON |
|---|---------------|-------------------|-----------------------|
| 1 | Fast gain | Front-panel knob | External signal |
| 2 | Slow feedback | Single integrator | Double integrator |
| 3 | Bias | Ramp to slow only | Ramp to fast and slow |
| 4 | External MOD | Disabled | Enabled |
| 5 | Offset | Normal | Fixed at midpoint |
| 6 | Sweep | Positive | Negative |
| 7 | Fast coupling | DC | AC |
| 8 | Fast offset | 0 | +2.5V |

- DIP 1** If ON, fast servo gain is determined by the potential applied to the rear-panel GAIN IN connector instead of the front-panel FAST GAIN knob.
- DIP 2** Slow servo is a single (OFF) or double (ON) integrator. Should be OFF if using “nested” slow and fast servo operation mode.
- DIP 3** If ON, generate a bias current in proportion to the slow servo output to prevent mode-hops. Only enable if not already provided by the laser controller. Should be OFF when the FSC is used in combination with a MOGLabs DLC.
- DIP 4** If ON, enables external modulation through the MOD IN connector on the rear panel. The modulation is added directly to FAST OUT. When enabled but not in use, the MOD IN input must be terminated to prevent undesired behaviour.
- DIP 5** If ON, disables the front-panel offset knob and fixes the offset to the mid-point. Useful in external sweep mode, to avoid accidentally

changing the laser frequency by bumping the offset knob.

- DIP 6** Reverses the direction of the sweep.
- DIP 7** Should normally be ON, so that the error signal is AC coupled to the feedback servos (time constant 40 ms/25 Hz). Switch OFF for DC coupling.
- DIP 8** If ON, a 2.5 V offset is added to the fast output, suitable for direct connection to MOGLabs B1047, B1240 headboards.

3. Feedback control loops

The FSC has two parallel feedback channels that can drive two actuators simultaneously: a “slow” actuator, typically used to change the laser frequency by a large amount on slow timescales, and a second “fast” actuator. The FSC provides precise control of each stage of the servo loop, as well as a sweep (ramp) generator and convenient signal monitoring.

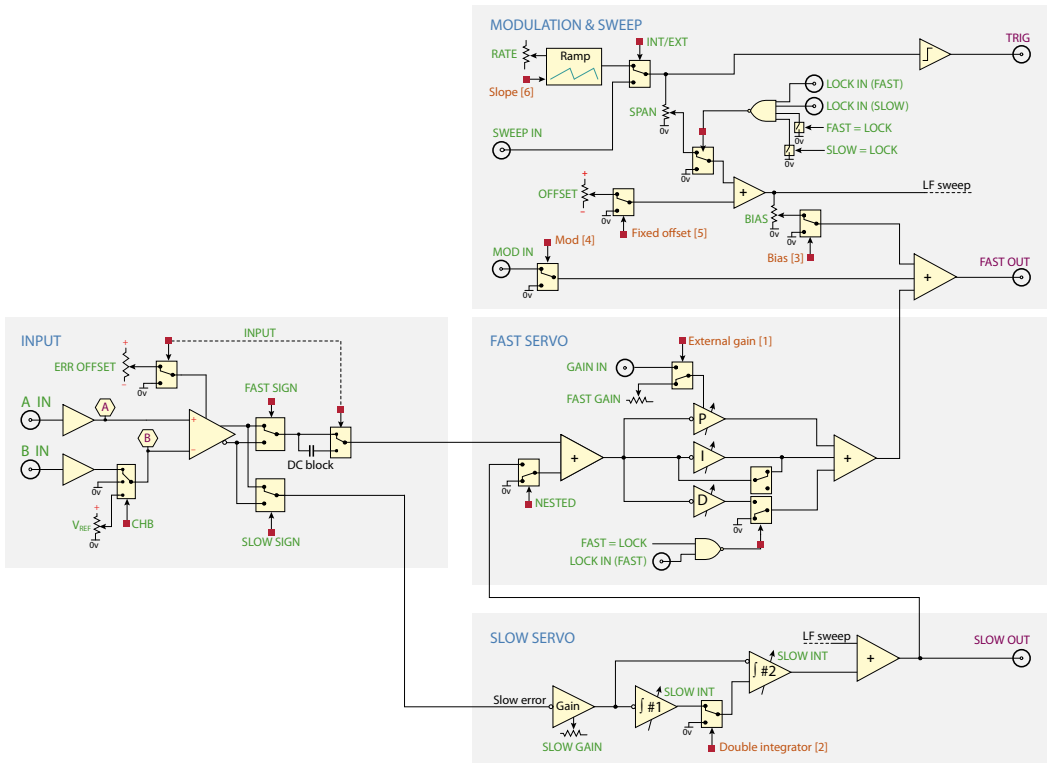

Figure 3.1: Schematic of the MOGLabs FSC. Green labels refer to controls on the front-panel and inputs on the back-panel, brown are internal DIP switches, and purple are outputs on the back-panel.

3.1 Input stage

The input stage of the FSC (figure 3.2) generates an *error signal* as $V_{ERR} = V_A - V_B - V_{OFFSET}$. V_A is taken from the “A IN” SMA connector, and V_B is set using the CHB selector switch, which chooses between the “B IN” SMA connector, $V_B = 0$ or $V_B = V_{REF}$ as set by the adjacent trimpot.

The controller acts to servo the error signal towards zero, which defines the lock point. Some applications may benefit from small adjustments to the DC level to adjust this lock point, which can be achieved with the 10-turn knob ERR OFFSET for up to ± 0.1 V shift, provided the INPUT selector is set to “offset” mode (Δ). Larger offsets can be achieved with the REF trimpot.

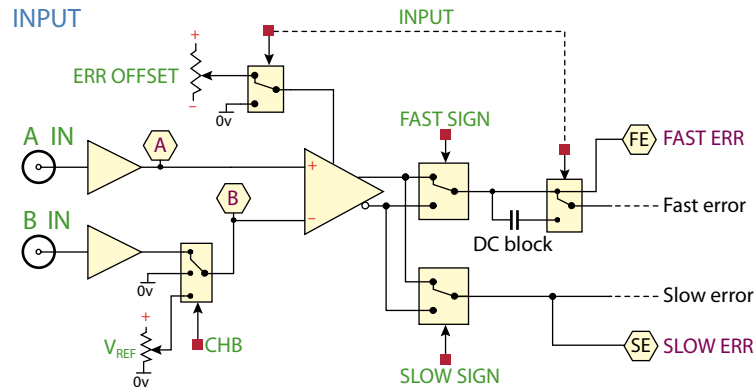

Figure 3.2: Schematic of the FSC input stage showing coupling, offset and polarity controls. Hexagons are monitored signals available via the front-panel monitor selector switches.

3.2 Slow servo loop

Figure 3.3 shows the slow feedback configuration of the FSC. A variable gain stage is controlled with the front-panel SLOW GAIN knob. The action of the controller is either a single- or double-integrator

depending on whether DIP2 is enabled. The slow integrator time constant is controlled from the front-panel SLOW INT knob, which is labelled in terms of the associated corner frequency.

SLOW SERVO

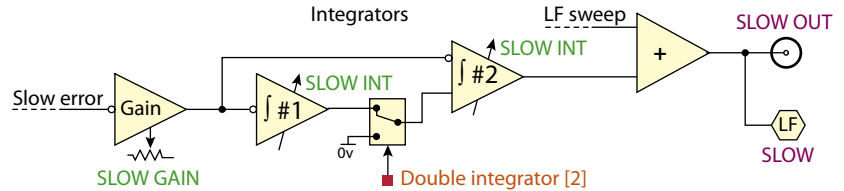

Figure 3.3: Schematic of slow feedback $1/I^2$ servo. Hexagons are monitored signals available via the front-panel selector switches.

With a single integrator, the gain increases with lower Fourier frequency, with slope of 20 dB per decade. Adding a second integrator increases the slope to 40 dB per decade, reducing the long-term offset between actual and setpoint frequencies. Increasing the gain too far results in oscillation as the controller “overreacts” to changes in the error signal. For this reason it is sometimes beneficial to restrict the gain of the control loop at low frequencies, where a large response can cause a laser mode-hop.

The slow servo provides large range to compensate for long-term drifts and acoustic perturbations, and the fast actuator has small range but high bandwidth to compensate for rapid disturbances. Using a double-integrator ensures that the slow servo has the dominant response at low frequency.

For applications that do not include a separate slow actuator, the slow control signal (single or double integrated error) can be added to the fast by setting the SLOW switch to “NESTED”. In this mode it is recommended that the double-integrator in the slow channel be disabled with DIP2 to prevent triple-integration.

3.2.1 Measuring the slow servo response

The slow servo loop is designed for slow drift compensation. To observe the slow loop response:

1. Set MONITOR 1 to SLOW ERR and connect the output to an oscilloscope.
2. Set MONITOR 2 to SLOW and connect the output to an oscilloscope.
3. Set INPUT to Δ (offset mode) and CHB to 0.
4. Adjust the ERR OFFSET knob until the DC level shown on the SLOW ERR monitor is close to zero.
5. Adjust the FREQ OFFSET knob until the DC level shown on the SLOW monitor is close to zero.
6. Set the volts per division on the oscilloscope to 10mV per division for both channels.
7. Engage the slow servo loop by setting SLOW mode to LOCK.
8. Slowly adjust the ERR OFFSET knob such that the DC level shown on the SLOW ERR monitor moves above and below zero by 10 mV.
9. As the integrated error signal changes sign, you will observe the slow output change by 50 mV.

Note that the response time for the slow servo to drift to its limit depends on a number of factors including the slow gain, the slow integrator time constant, single or double integration, and the size of the error signal.

3.2.2 Slow output voltage swing

The output of the slow servo control loop is configured for a range of 0 to 2.5 V for compatibility with a MOGLabs DLC . The DLC SWEEP piezo control input has a voltage gain of 48 so that the maximum input of 2.5 V results in 120 V on the piezo. When the slow servo loop is engaged, the slow output will only swing by ± 25 mV relative to its value prior to engagement. This limitation is intentional, to avoid laser mode hops. When the slow output of the FSC is used with a MOGLabs DLC , a 50 mV swing in the output of the slow channel of the FSC corresponds to a 2.4 V swing in the piezo voltage which corresponds to a change in laser frequency of around 0.5 to 1 GHz, comparable to the free spectral range of a typical reference cavity.

For use with different laser controllers, a larger change in the locked slow output of the FSC can be enabled via a simple resistor change. The gain on the output of the slow feedback loop is defined by $R82/R87$, the ratio of resistors R82 (500 Ω) and R87 (100 k Ω). To increase the slow output, increase $R82/R87$, most easily accomplished by reducing R87 by piggybacking another resistor in parallel (SMD package, size 0402). For example, adding a 30 k Ω resistor in parallel with the existing 100 k Ω resistor would give an effective resistance of 23 k Ω providing an increase in the slow output swing from ± 25 mV to ± 125 mV. Figure 3.4 shows the layout of the FSC PCB around opamp U16.

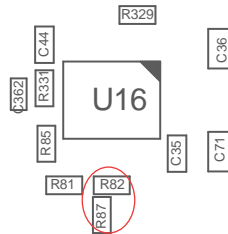

Figure 3.4: The FSC PCB layout around the final slow gain opamp U16, with gain setting resistors R82 and R87 (circled); size 0402.

3.3 Fast servo loop

The fast feedback servo (figure 3.5) is a PID-loop which provides precise control over each of the proportional (P), integral (I) and differential (D) feedback components, as well as the overall gain of the entire system. The fast output of the FSC can swing from -2.5 V to 2.5 V which, when configured with a MOGLabs external cavity diode laser, can provide a swing in current of ± 2.5 mA.

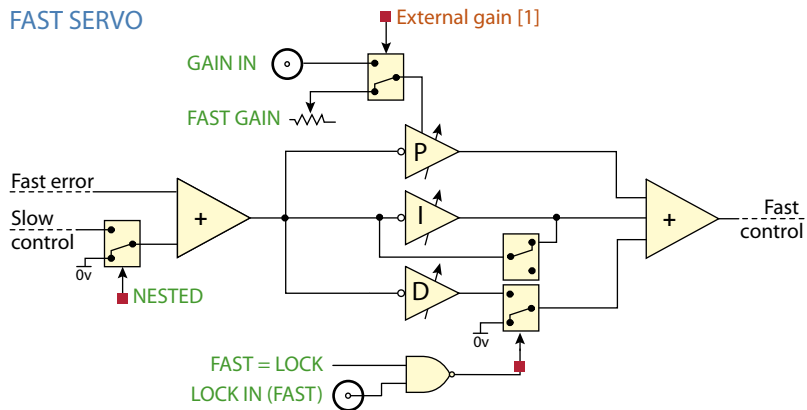

Figure 3.5: Schematic of fast feedback servo PID controller.

Figure 3.6 shows a conceptual plot of the action of both the fast and slow servo loops. At low frequencies, the fast integrator (I) loop dominates. To prevent the fast servo loop over-reacting to low frequency (acoustic) external perturbations, a low-frequency gain limit is applied controlled by the GAIN LIMIT knob.

At mid-range frequencies (10 kHz–1 MHz) the proportional (P) feedback dominates. The unity gain corner frequency at which the proportional feedback exceeds the integrated response is controlled by the FAST INT knob. The overall gain of the P loop is set by the FAST GAIN trimpot, or via an external control signal through the rear-panel GAIN IN connector.

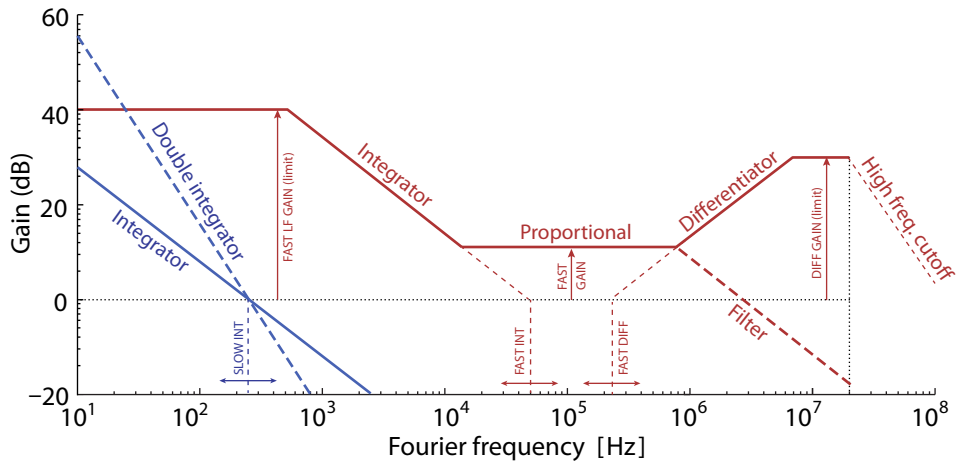

Figure 3.6: Conceptual Bode plot showing action of the fast (red) and slow (blue) controllers. The slow controller is either a single or double integrator with adjustable corner frequency. The fast controller is a PID compensator with adjustable corner frequencies and gain limits at the low and high frequencies. Optionally the differentiator can be disabled and replaced with a low-pass filter.

High frequencies (1 MHz) typically require the differentiator loop to dominate for improved locking. The differentiator provides phase-lead compensation for the finite response time of the system and has gain that increases at 20 dB per decade. The corner frequency of the differential loop can be adjusted via the FAST DIFF/FILTER knob to control the frequency at which differential feedback dominates. If the FAST DIFF/FILTER is set to OFF, then the differential loop is disabled and the feedback remains proportional at higher frequencies. To prevent oscillation and limit the influence of high-frequency noise when the differential feedback loop is engaged, there is an adjustable gain limit, DIFF GAIN, that restricts the differentiator at high frequencies.

A differentiator is often not required, and the compensator may instead benefit from low-pass filtering of the fast servo response to further reduce the influence of noise. Rotate the FAST DIFF/FILTER

knob anti-clockwise from the OFF position to set the roll-off frequency for filtering mode.

The fast servo has three modes of operation: SCAN, SCAN+P and LOCK. When set to SCAN, feedback is disabled and only the bias is applied to the fast output. When set to SCAN+P, proportional feedback is applied, which allows for determination of the fast servo sign and gain while the laser frequency is still scanning, simplifying the locking and tuning procedure (see §4.2). In LOCK mode, the scan is halted and full PID feedback is engaged.

3.3.1 *Measuring the fast servo response*

The following two sections describe measurement of proportional and differential feedback to changes in the error signal. Use a function generator to simulate an error signal, and an oscilloscope to measure the response.

1. Connect MONITOR 1, 2 to an oscilloscope, and set the selectors to FAST ERR and FAST .
2. Set INPUT to Δ (offset mode) and CHB to 0.
3. Connect the function generator to CHA input.
4. Configure the function generator to produce a 100 Hz sine wave of 20 mV peak to peak.
5. Adjust the ERR OFFSET knob such that the sinusoidal error signal, as seen on the FAST ERR monitor, is centred about zero.

3.3.2 *Measuring the proportional response*

- Reduce the span to zero by turning the SPAN knob fully anti-clockwise.
- Set FAST to SCAN+P to engage the proportional feedback loop.

- On the oscilloscope, the FAST output of the FSC should show a 100 Hz sine wave.
- Adjust the FAST GAIN knob to vary the proportional gain of the fast servo until the output is the same amplitude as the input.
- To measure the proportional feedback frequency response, adjust the frequency of the function generator and monitor the amplitude of the FAST output response. For example, increase the frequency until the amplitude is halved, to find the -3 dB gain frequency.

3.3.3 Measuring the differential response

1. Set FAST INT to OFF to switch off the integrator loop.
2. Set the FAST GAIN to unity using the steps described in the section above.
3. Set the DIFF GAIN to 0 dB.
4. Set FAST DIFF/FILTER to 100 kHz.
5. Sweep the frequency of the function generator from 100 kHz to 3 MHz and monitor the FAST output.
6. As you sweep the error signal frequency, you should see unity gain at all frequencies.
7. Set the DIFF GAIN to 24 dB.
8. Now as you sweep the error signal frequency, you should notice a 20 dB per decade slope increase after 100 kHz that will start to roll off at 1 MHz, showing the opamp bandwidth limitations.

The gain of the fast output can be altered by changing resistor values, but the circuit is more complicated than for slow feedback (§3.2.2). Contact MOGLabs for further information if required.

3.4 Modulation and scanning

Laser scanning is controlled by either an internal sweep generator or an external sweep signal. The internal sweep is a sawtooth with variable period as set by an internal four-position range switch (App. C), and a single-turn trimpot RATE on the front-panel.

The fast and slow servo loops can be individually engaged via TTL signals to the rear-panel associated front-panel switches. Setting either loop to LOCK stops the sweep and activates stabilisation.

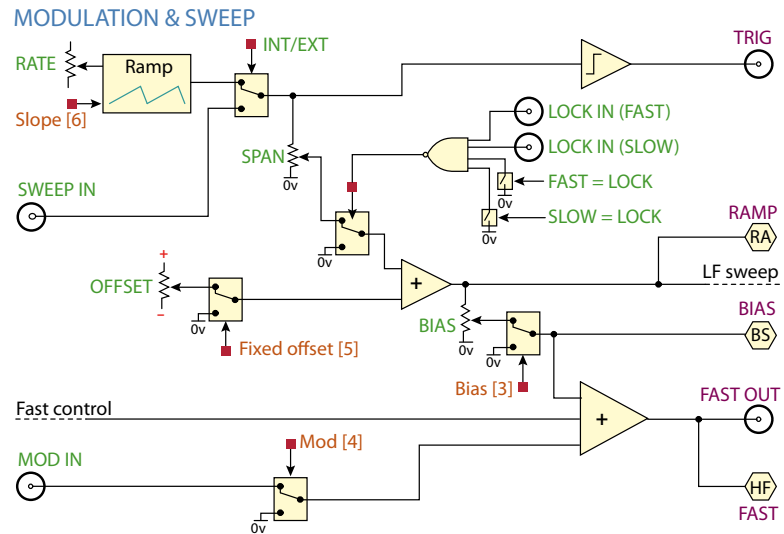

Figure 3.7: Sweep, external modulation, and feedforward current bias.

The ramp can also be added to the fast output by enabling DIP3 and adjusting the BIAS trimpot, but many laser controllers (such as the MOGLabs DLC) will generate the necessary bias current based on the slow servo signal, in which case it is unnecessary to also generate it within the FSC.

4. Application example: Pound-Drever Hall locking

A typical application of the FSC is to frequency-lock a laser to an optical cavity using the PDH technique (fig. 4.1). The cavity acts as a frequency discriminator, and the FSC keeps the laser on resonance with the cavity by controlling the laser piezo and current through its SLOW and FAST outputs respectively, reducing the laser linewidth. A separate application note (AN002) is available that provides detailed practical advice on implementing a PDH apparatus.

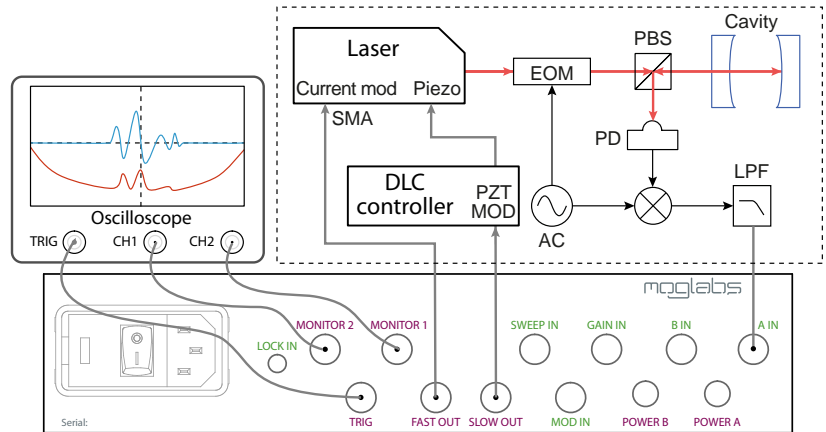

Figure 4.1: Simplified schematic for PDH-cavity locking using the FSC. An electro-optic modulator (EOM) generates sidebands, which interact with the cavity, generating reflections that are measured on the photodetector (PD). Demodulating the photodetector signal produces a PDH error signal.

A variety of other methods can be used to generate error signals, which will not be discussed here. The rest of this chapter describes how to achieve a lock once an error signal has been generated.

4.1 Laser and controller configuration

The FSC is compatible with a variety of lasers and controllers, provided they are correctly configured for the desired mode of operation. When driving an ECDL (such as the MOGLabs CEL or LDL lasers), the requirements for the laser and controller are as follows:

- High-bandwidth modulation directly into the laser headboard or intra-cavity phase modulator.
- High-voltage piezo control from an external control signal.
- Feed-forward (“bias current”) generation for lasers that require a bias of $\gtrsim 1$ mA across their scan range. The FSC is capable of generating a bias current internally but the range might be limited by headboard electronics or phase modulator saturation, so it may be necessary to use bias provided by the laser controller.

MOGLabs laser controllers and headboards can be easily configured to achieve the required behaviour, as explained below.

4.1.1 Headboard configuration

MOGLabs lasers include an internal headboard that interfaces the components with the controller. A headboard that includes fast current modulation via an SMA connector is required for operation with the FSC. The headboard should be connected directly to the FSC FAST OUT.

The B1240 headboard is strongly recommended for maximum modulation bandwidth, although the B1040 and B1047 are acceptable substitutes for lasers that are incompatible with the B1240. The headboard has a number of jumper switches which must be configured for **DC coupled** and **buffered** (BUF) input, where applicable.

4.1.2 DLC configuration

Although the FSC can be configured for either internal or external sweep, it is significantly simpler to use the internal sweep mode and set the DLC as a slave device as follows:

1. Connect SLOW OUT to SWEEP / PZT MOD on the DLC .
2. Enable DIP9 (*External sweep*) on the DLC . Ensure that DIP13 and DIP14 are off.
3. Disable DIP3 (*Bias generation*) of the FSC. The DLC automatically generates the current feed-forward bias from the sweep input, so it is not necessary to generate a bias within the FSC.
4. Set SPAN on the DLC to maximum (fully clockwise).
5. Set FREQUENCY on the DLC to zero using the LCD display to show *Frequency*.
6. Ensure that SWEEP on the FSC is INT.
7. Set FREQ OFFSET to mid-range and SPAN to full on the FSC and observe the laser scan.
8. If the scan is in the wrong direction, invert DIP4 of the FSC or DIP11 of the DLC .

It is important that the SPAN knob of the DLC is not adjusted once set as above, as it will impact the feedback loop and may prevent the FSC from locking. The FSC controls should be used to adjust the sweep.

4.2 Achieving an initial lock

The SPAN and OFFSET controls of the FSC can be used to tune the laser to sweep across the desired lock point (e.g. cavity resonance) and to zoom into a smaller scan around the resonance. The following

steps are illustrative of the process required to achieve a stable lock. Values listed are indicative, and will need to be adjusted for specific applications. Further advice on optimising the lock is provided in §4.3.

4.2.1 Locking with fast feedback

1. Connect the error signal to the A IN input on the back-panel.
2. Ensure that the error signal is of order 10 mVpp.
3. Set INPUT to Δ (offset mode) and CHB to 0.
4. Set MONITOR 1 to FAST ERR and observe on an oscilloscope. Adjust the ERR OFFSET knob until the DC level shown is zero. If there is no need to use the ERROR OFFSET knob to adjust the DC level of the error signal, the INPUT switch can be set to DC and the ERROR OFFSET knob will have no effect, preventing accidental adjustment.
5. Reduce the FAST GAIN to zero.
6. Set FAST to SCAN+P, set SLOW to SCAN, and locate the resonance using the sweep controls.
7. Increase FAST GAIN until the error signal is seen to “stretch out” as shown in figure 4.2. If this is not observed, invert the FAST SIGN switch and try again.
8. Set FAST DIFF to OFF and GAIN LIMIT to 40. Reduce FAST INT to 100 kHz.
9. Set FAST mode to LOCK and the controller will lock to the zero-crossing of the error signal. It may be necessary to make small adjustments to FREQ OFFSET to lock the laser.
10. Optimise the lock by adjusting the FAST GAIN and FAST INT while observing the error signal. It may be necessary to relock the servo after adjusting the integrator.

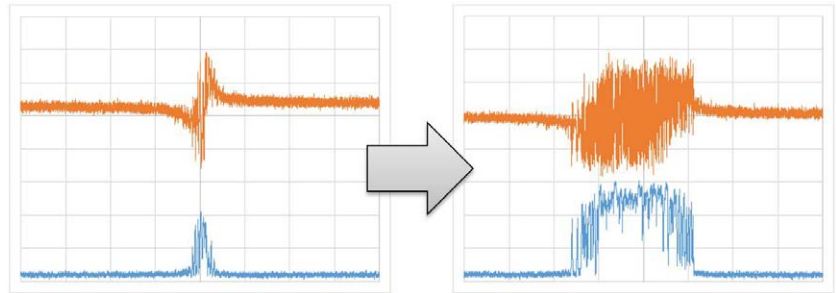

Figure 4.2: Scanning the laser with P-only feedback on the fast output while scanning the slow output causes the error signal (orange) to become extended when the sign and gain are correct (right). In a PDH application, the cavity transmission (blue) will also become extended.

11. Some applications may benefit by increasing FAST DIFF to improve loop response, but this is typically not needed to achieve an initial lock.

4.2.2 Locking with slow feedback

Once lock is achieved with the fast proportional and integrator feedback, the slow feedback should then be engaged to account for slow drifts and sensitivity to low frequency acoustic perturbations.

1. Set SLOW GAIN to mid-range and SLOW INT to 100 Hz.
2. Set FAST mode to SCAN+P to unlock the laser, and adjust SPAN and OFFSET so that you can see the zero crossing.
3. Set MONITOR 2 to SLOW ERR and observe on an oscilloscope. Adjust the trimpot beside ERR OFFSET to bring the slow error signal to zero. Adjusting this trimpot will only affect the DC level of the slow error signal, not the fast error signal.
4. Relock the laser by setting FAST mode to LOCK and make any necessary small adjustments to FREQ OFFSET to lock the laser.

5. Set SLOW mode to LOCK and observe the slow error signal. If the slow servo locks, the DC level of the slow error may change. If this occurs, note the new value of the error signal, set SLOW back to SCAN and use the error offset trimpot to bring the slow unlocked error signal closer to the locked value and try relocking the slow lock.
6. Iterate the previous step of slow locking the laser, observing the DC change in the slow error, and adjusting the error offset trimpot until engaging the slow lock does not produce a measurable change in the slow locked versus fast locked error signal value.

The error offset trimpot adjusts for small (mV) differences in the fast and slow error signal offsets. Adjusting the trimpot ensures that both the fast and slow error compensator circuits lock the laser to the same frequency.

7. If the servo unlocks immediately upon engaging the slow lock, try inverting the SLOW SIGN.
8. If the slow servo still unlocks immediately, reduce the slow gain and try again.
9. Once a stable slow lock is achieved with the ERR OFFSET trimpot correctly set, adjust SLOW GAIN and SLOW INT for improved lock stability.

4.3 Optimisation

The purpose of the servo is to lock the laser to the zero-crossing of the error signal, which ideally would be identically zero when locked. Noise in the error signal is therefore a measure of lock quality. Spectrum analysis of the error signal is a powerful tool for understanding and optimising the feedback. RF spectrum analysers can be used but are comparatively expensive and have limited dynamic range. A good sound card (24-bit 192 kHz, e.g. Lynx L22)

provides noise analysis up to a Fourier frequency of 96 kHz with 140 dB dynamic range.

Ideally the spectrum analyser would be used with an independent frequency discriminator that is insensitive to laser power fluctuations [11]. Good results can be achieved by monitoring the in-loop error signal but an out-of-loop measurement is preferable, such as measuring the cavity transmission in a PDH application. To analyse the error signal, connect the spectrum analyser to one of the MONITOR outputs set to FAST ERR.

High-bandwidth locking typically involves first achieving a stable lock using only the fast servo, and then using the slow servo to improve the long-term lock stability. The slow servo is required to compensate for thermal drift and acoustic perturbations, which would result in a mode-hop if compensated with current alone. In contrast, simple locking techniques such as saturated absorption spectroscopy are typically achieved via first achieving a stable lock with the slow servo, and then using the fast servo to compensate for higher-frequency fluctuations only. It may be beneficial to consult the Bode plot (figure 4.3) when interpreting the error signal spectrum.

When optimising the FSC, it is recommended to first optimise the fast servo through analysis of the error signal (or transmission through the cavity), and then the slow servo to reduce sensitivity to external perturbations. In particular, SCAN+P mode provides a convenient way to get the feedback sign and gain approximately correct.

Note that achieving the most stable frequency lock requires careful optimisation of many aspects of the apparatus, not just the parameters of the FSC. For example, residual amplitude modulation (RAM) in a PDH apparatus results in drift in the error signal, which the servo is unable to compensate for. Similarly, poor signal-to-noise ratio (SNR) will feed noise directly into the laser.

In particular, the high gain of the integrators means that the lock can be sensitive to ground loops in the signal-processing chain, and

care should be taken to eliminate or mitigate these. The earth of the FSC should be as close as possible to both the laser controller and any electronics involved in generating the error signal.

One procedure for optimising the fast servo is to set FAST DIFF to OFF and adjust FAST GAIN, FAST INT and GAIN LIMIT to reduce the noise level as far as possible. Then optimise the FAST DIFF and DIFF GAIN to reduce the high-frequency noise components as observed on a spectrum analyser. Note that changes to FAST GAIN and FAST INT may be required to optimise the lock once the differentiator has been introduced.

In some applications, the error signal is bandwidth-limited and only contains uncorrelated noise at high frequencies. In such scenarios it is desirable to limit the action of the servo at high frequencies to prevent coupling this noise back into the control signal. A *filter* option is provided to reduce the fast servo response above a specific frequency. This option is mutually-exclusive to the differentiator, and should be tried if enabling the differentiator is seen to increase

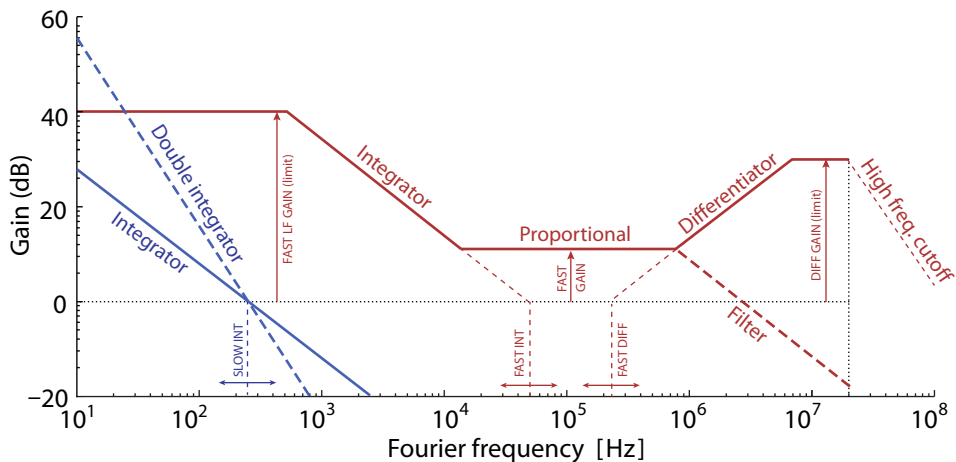

Figure 4.3: Conceptual Bode plot showing action of the fast (red) and slow (blue) controllers. The corner frequencies and gain limits are adjusted with the front-panel knobs as labelled.

the measured noise.

The slow servo can then be optimised to minimise the over-reaction to external perturbations. Without the slow servo loop the high gain limit means that the fast servo will respond to external perturbations (e.g. acoustic coupling) and the resulting change in current can induce mode-hops in the laser. It is therefore preferable that these (low-frequency) fluctuations are compensated in the piezo instead.

Adjusting the SLOW GAIN and SLOW INT will not necessarily produce an improvement in the error signal spectrum, but when optimised will reduce the sensitivity to acoustic perturbations and prolong the lifetime of the lock.

Similarly, activating the double-integrator (DIP2) may improve stability by ensuring that the overall gain of the slow servo system is higher than the fast servo at these lower frequencies. However, this may cause the slow servo to overreact to low-frequency perturbations and the double-integrator is only recommended if long-term drifts in current are destabilising the lock.

A. Specifications

| Parameter | Specification |
|-----------|---------------|
|-----------|---------------|

| Timing | |
|--|------------|
| Gain bandwidth (-3 dB) | > 35 MHz |
| Propagation delay | < 40 ns |
| External modulation bandwidth (-3 dB) | > 35 MHz |

| Input | |
|------------|--|
| A IN, B IN | SMA, $1\text{ M}\Omega$, $\pm 2.5\text{ V}$ |
| SWEEP IN | SMA, $1\text{ M}\Omega$, 0 to $+2.5\text{ V}$ |
| GAIN IN | SMA, $1\text{ M}\Omega$, $\pm 2.5\text{ V}$ |
| MOD IN | SMA, $1\text{ M}\Omega$, $\pm 2.5\text{ V}$ |
| LOCK IN | 3.5 mm female audio connector, TTL |

Analogue inputs are over-voltage protected up to $\pm 10\text{ V}$.
TTL inputs take $< 1.0\text{ V}$ as low, $> 2.0\text{ V}$ as high.
LOCK IN inputs are -0.5 V to 7 V , active low, drawing $\pm 1\text{ }\mu\text{A}$.

| Parameter | Specification |
|---------------|---|
| Output | |
| SLOW OUT | SMA, 50 Ω , 0 to +2.5 V, BW 20 kHz |
| FAST OUT | SMA, 50 Ω , ± 2.5 V, BW > 20 MHz |
| MONITOR 1, 2 | SMA, 50 Ω , BW > 20 MHz |
| TRIG | SMA, 0 to +5 V |
| POWER A, B | M8 female connector, ± 12 V, 125 mA |

All outputs are limited to ± 5 V.
 50 Ω outputs 20 mA max (20 mW, +13 dBm).

| | |
|-------------------------------|---|
| Mechanical & power | |
| IEC input | 110 to 130V at 60Hz or 220 to 260V at 50Hz |
| Fuse | 5x20mm anti-surge ceramic 250 V/2.5 A |
| Dimensions | W×H×D = 250 × 79 × 292 mm |
| Weight | 2 kg |
| Power usage | < 10 W |

B. Troubleshooting

B.1 Laser frequency not scanning

A MOGLabs DLC with external piezo control signal requires that the external signal must cross 1.25 V. If you are sure your external control signal crosses 1.25 V confirm the following:

- DLC span is fully clockwise.
- FREQUENCY on the DLC is zero (using the LCD display to set *Frequency*).
- DIP9 (*External sweep*) of the DLC is on.
- DIP13 and DIP14 of the DLC are off.
- The lock toggle switch on the DLC is set to SCAN.
- SLOW OUT of the FSC is connected to the SWEEP / PZT MOD input of the DLC .
- SWEEP on the FSC is INT.
- FSC span is fully clockwise.
- Connect the FSC MONITOR 1 to an oscilloscope, set the MONITOR 1 knob to RAMP and adjust FREQ OFFSET until the ramp is centred about 1.25 V.

If the above checks have not solved your problem, disconnect the FSC from the DLC and ensure that the laser scans when controlled with the DLC . Contact MOGLabs for assistance if not successful.

B.2 When using modulation input, the fast output floats to a large voltage

When using the MOD IN functionality of the FSC (DIP 4 enabled) the fast output will typically float to the positive voltage rail, around 4V. Ensure MOD IN is shorted when not in use.

B.3 Large positive error signals

In some applications, the error signal generated by the application may be strictly positive (or negative) and large. In this case the REF trimpot and ERR OFFSET may not provide sufficient DC shift to ensure the desired lockpoint coincides with 0 V. In this case both CH A and CH B can be used with the INPUT toggle set to Δ , CH B set to PD and with a DC voltage applied to CH B to generate the offset needed to centre the lock point. As an example, if the error signal is between 0 V and 5 V and the lock point was 2.5 V, then connect the error signal to CH A and apply 2.5 V to CH B. With the appropriate setting the error signal will then be between -2.5 V to $+2.5$ V.

B.4 Fast output rails at ± 0.625 V

For most MOGLabs ECDLs, a voltage swing of ± 0.625 V on the fast output (corresponding to ± 0.625 mA injected into the laser diode) is more than required for locking to an optical cavity. In some applications a larger range on the fast output is required. This limit can be increased by a simple resistor change. Please contact MOGLabs for more information if required.

B.5 Feedback needs to change sign

If the fast feedback polarity changes, it is typically because the laser has drifted into into a multi-mode state (two external cavity modes oscillating simultaneously). Adjust the laser current to obtain singlemode operation, rather than reversing the feedback polarity.

B.6 Monitor outputs wrong signal

During factory testing, the output of each of the MONITOR knobs is verified. However, over time the set screws that hold the knob in position can relax and the knob may slip, causing the knob to indicate the wrong signal. To check:

- Connect the output of the MONITOR to an oscilloscope.
- Turn the SPAN knob fully clockwise.
- Turn the MONITOR to RAMP. You should now observe a ramping signal on the order of 1 volt; if you do not then the knob position is incorrect.
- Even if you do observe a ramping signal, the knob position may still be wrong, turn the knob one position more clockwise.
- You should now have a small signal near 0 V, and perhaps can see a small ramp on the oscilloscope on the order of tens of mV. Adjust the BIAS trimpot and you should see the amplitude of this ramp change.
- If the signal on the oscilloscope changes as you adjust the BIAS trimpot your MONITOR knob position is correct; if not, then the MONITOR knob position needs to be adjusted.

To correct the MONITOR knob position, the output signals must first be identified using a similar procedure to above, and the knob position can then be rotated by loosening the two set screws that hold the knob in place, with a 1.5 mm allen key or ball driver.

B.7 Laser undergoes slow mode hops

Slow mode hops can be caused by optical feedback from optical elements between the laser and the cavity, for example fibre couplers, or from the optical cavity itself. Symptoms include frequency

jumps of the free-running laser on slow timescales, of the order of 30 s where the laser frequency jumps by 10 to 100 MHz. Ensure the laser has sufficient optical isolation, installing another isolator if necessary, and block any beam paths that are unused.

C. PCB layout

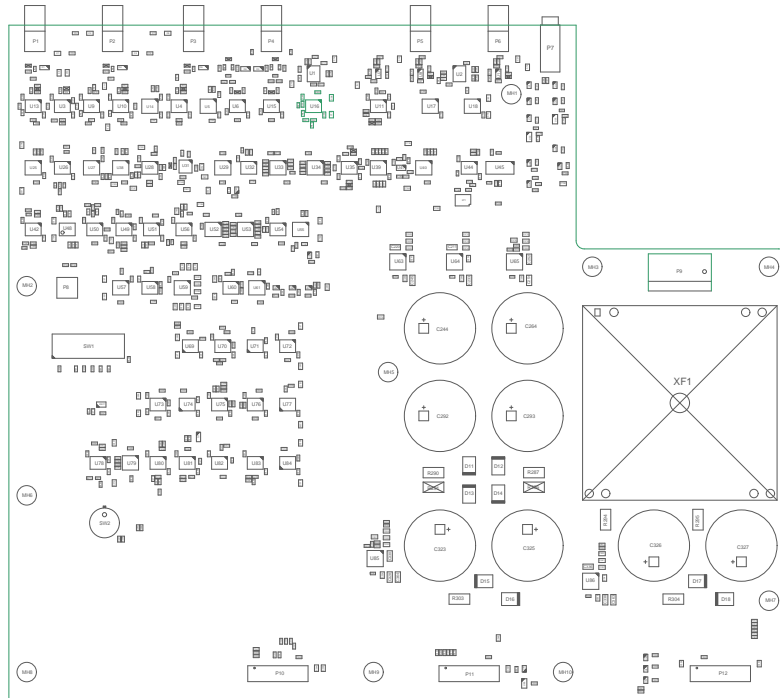

D. 115/230 V conversion

D.1 Fuse

The fuse is a ceramic antisurge, 2.5A, 5x20mm, for example Littlefuse 021502.5MXP. The fuse holder is a red cartridge just above the IEC power inlet and main switch on the rear of the unit (Fig. D.1).



Figure D.1: Fuse cartridge, showing fuse placement for operation at 230 V.

D.2 120/240 V conversion

The controller can be powered from AC at 50 to 60 Hz, 110 to 120 V (100 V in Japan), or 220 to 240 V. To convert between 115 V and 230 V, the fuse cartridge should be removed, and re-inserted such that the correct voltage shows through the cover window.



Figure D.2: To change fuse or voltage, open the fuse cartridge cover with a screwdriver inserted into a small slot at the left edge of the cover, just to the left of the red voltage indicator.

When removing the fuse cartridge, insert a screwdriver into the recess at the *left* of the cartridge; do not try to extract using a screwdriver at the sides of the fuseholder (see figures).

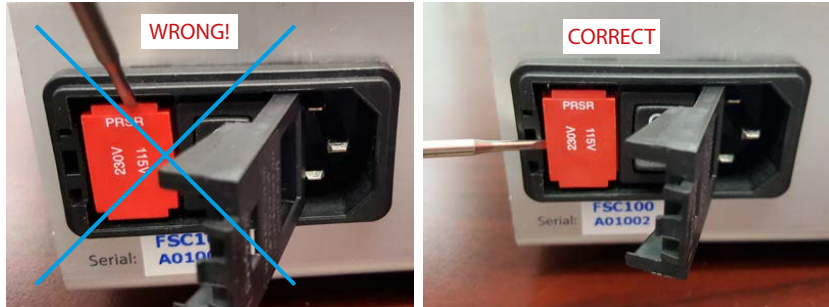

Figure D.3: To extract the fuse cartridge, insert a screwdriver into a recess at the *left* of the cartridge.

When changing the voltage, the fuse and a bridging clip must be swapped from one side to the other, so that the bridging clip is always on the bottom and the fuse always on the top; see figures below.

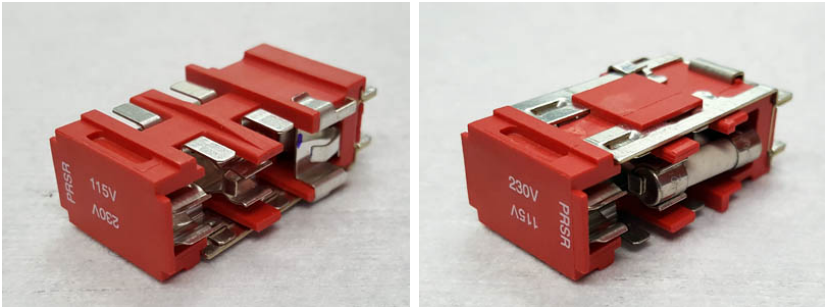

Figure D.4: 230 V bridge (left) and fuse (right). Swap the bridge and fuse when changing voltage, so that the fuse remains uppermost when inserted.

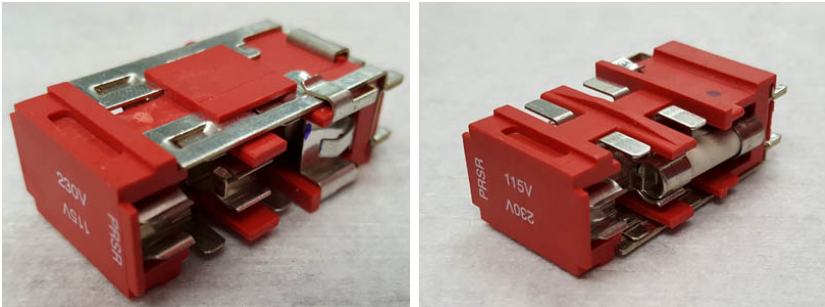

Figure D.5: 115 V bridge (left) and fuse (right).

Bibliography

- [1] Alex Abramovici and Jake Chapsky. *Feedback Control Systems: A Fast-Track Guide for Scientists and Engineers*. Springer Science & Business Media, 2012. 1
- [2] Boris Lurie and Paul Enright. *Classical Feedback Control: With MATLAB® and Simulink®*. CRC Press, 2011. 1
- [3] Richard W. Fox, Chris W. Oates, and Leo W. Hollberg. Stabilizing diode lasers to high-finesse cavities. *Experimental methods in the physical sciences*, 40:1–46, 2003. 1
- [4] R. W. P. Drever, J. L. Hall, F. V. Kowalski, J. Hough, G. M. Ford, A. J. Munley, and H. Ward. Laser phase and frequency stabilization using an optical resonator. *Appl. Phys. B*, 31:97–105, 1983. 1
- [5] T. W. Hänsch and B. Couillaud. Laser frequency stabilization by polarization spectroscopy of a reflecting reference cavity. *Optics communications*, 35(3):441–444, 1980. 1
- [6] M. Zhu and J. L. Hall. Stabilization of optical phase/frequency of a laser system: application to a commercial dye laser with an external stabilizer. *J. Opt. Soc. Am. B*, 10:802, 1993. 1
- [7] G. C. Bjorklund. Frequency-modulation spectroscopy: a new method for measuring weak absorptions and dispersions. *Opt. Lett.*, 5:15, 1980. 1
- [8] Joshua S Torrance, Ben M Sparkes, Lincoln D Turner, and Robert E Scholten. Sub-kilohertz laser linewidth narrowing using polarization spectroscopy. *Optics express*, 24(11):11396–11406, 2016. 1

- [9] S. C. Bell, D. M. Heywood, J. D. White, and R. E. Scholten. Laser frequency offset locking using electromagnetically induced transparency. *Appl. Phys. Lett.*, 90:171120, 2007. 1
- [10] W. Demtröder. *Laser Spectroscopy, Basic Concepts and Instrumentation*. Springer, Berlin, 2e edition, 1996. 1
- [11] L. D. Turner, K. P. Weber, C. J. Hawthorn, and R. E. Scholten. Frequency noise characterization of narrow linewidth diode lasers. *Opt. Communic.*, 201:391, 2002. 29

